

DGOZ-DINRLY-12A-01 / DGOZ-DINRLY-12A-02 - RAPIX DALI-2 DIN Mount Relays

Product summary and capabilities

These one and two channel DALI Relays have voltage-free contacts. Each channel is suitable for on/off switching of up to 12 A of lighting load using DALI commands.

A convenient DIN mount enclosure makes these products suitable for switchboard installation. The on-board relay can switch a full 12 A of LED, incandescent, fluorescent, and HID lighting loads, making it suitable for a wide range of commercial and industrial building applications.

To maximise contact life, these Relays include a proprietary zero cross turn on feature. The load is switched on at the mains voltage zero-crossing point, helping to reduce the effects of inrush current and maximise contact life.

This product is DALI-2 certified and suitable for use in DALI and DALI-2 systems.

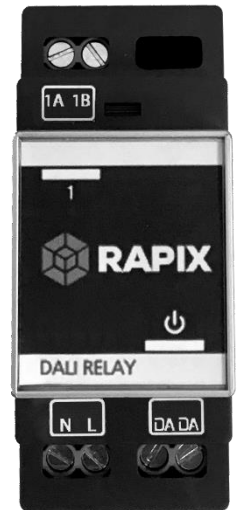

Product Features

- General purpose load switching (ON and OFF) via received DALI commands.
- Capable of switching 12 AX at voltages from 100 - 240 V ac.
- Very high inrush current rating.
- Zero crossing detection to maximise relay contact life.
- Voltage free contacts.
- LED indicators (DALI and each load channel).
- Each channel uses a single DALI Short Address.
- Each channel can be included in up to 16 DALI Group Addresses and/or up to 16 DALI Scenes.
- DALI Short Address, Group Addresses and DALI Scenes are configured using **RAPIX Addressing** or **RAPIX Integrator** software. Can also be commissioned using other DALI commissioning software that supports DALI Device Type 7.
- Complies with DALI standard IEC 62386 (Ed 2 – DALI-2) and Device Type 7 (Switching Function).

Important notes and safety information



WARNING – Electric shock may result in serious injury or death. Follow all warnings in this guide and on the product. Work in accordance with the latest electrical safety practices.

- These DALI Relays require a mains supply connection and are mounted on DIN rail.
- The installer must be suitably qualified and should work in accordance with standard safety procedures for mains-powered electrical equipment.
- DALI system wiring is only single insulated from mains. **Treat DALI wiring the same as mains wiring.**
- There are **no user serviceable parts** inside the DALI Relays. Do not attempt to disassemble or operate the device with any covers removed.
- These DALI Relays are for **indoor use only**.

Use with SELV Systems



WARNING – The relay contacts of this product are voltage-free and have Basic Insulation from mains voltages. This product does not have Double Insulation between mains and relay contacts (as would be required for connection to Safety Extra Low Voltage systems). Therefore:

THE RELAY CONTACTS ARE NOT SUITABLE FOR CONNECTION TO SAFETY EXTRA LOW VOLTAGE (SELV) SYSTEMS.

For a DALI SELV relay, the RAPIX DALI Low Power Voltage-Free Relay, order code DGOZ-LPVFR-11, is suitable for dc switching and SELV applications.

Use with Multiple Phases



WARNING – THE TWO CHANNEL RELAY IS NOT SUITABLE FOR USE WHERE EACH CHANNEL SWITCHES A DIFFERENT PHASE.

USE SEPARATE ONE CHANNEL RELAYS FOR THAT APPLICATION.

Installation and Wiring

The DALI Relay is mounted on DIN rail which should be installed horizontally in a suitable switchboard enclosure. Multiple DALI Relays, DALI power supplies, controllers or other devices can be mounted on the same DIN rail.

All terminals allow 3 x 1.5 mm² or 2 x 2.5 mm² (solid or stranded) wire per tunnel.

The Channel 1 and Channel 2 connection are voltage-free, and polarity independent.

For correct operation, be sure that the mains power supply and the load use the same phase.

Commissioning

To operate correctly, the DALI Relay must be programmed with the appropriate DALI addresses. Depending on application, the following parameters may need to be configured:

- DALI Short Address;
- DALI Group Address(s);
- DALI Scene Address(s);
- Minimum Level and Maximum Level;
- Power On Level and System Failure Level;
- Fade Times; and
- Switching Thresholds.

These parameters can be configured using **RAPIX** software, or any other DALI software which allows these standard DALI parameters to be configured in a DALI Compliant Relay device.

Operation and Indicators

The unit has indicators for displaying the mains power and DALI line status, as well as the ON/OFF state of each channel.

Mains Supply and DALI Line Indicator

Indicator	Operation
Green: On with short blink OFF every 2 seconds	Mains Power is present. DALI Power is present.
Green: Off with short blink ON every 2 seconds	Mains Power is present. DALI Power is not present.
Green: multiple fast blinks	Mains Power and DALI Power are present. There is communication on the DALI line.
Off	No Mains Power.

Channel Status Indicator

Indicator	Operation
Green – on	The Channel is switched ON.
Off	The Channel is switched OFF.

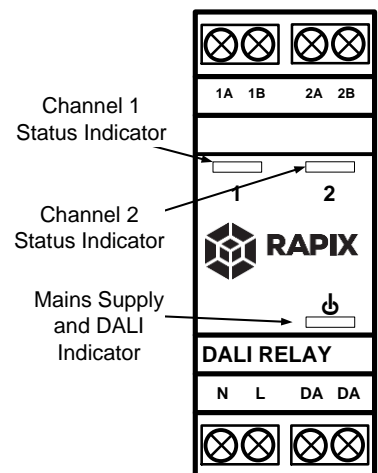
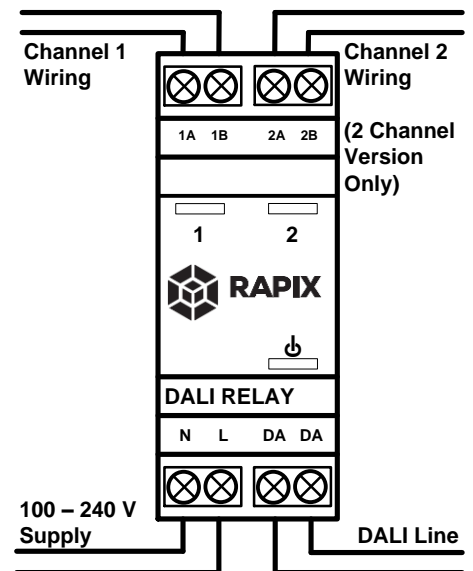

Standards and compliance

The product is designed to meet/exceed the following Australian and International standards:

EMC and Electrical Safety Frameworks and Standards

IEC/EN 60669-2-1, AS/NZS 60669.2.1
 IEC/EN 61000-3-2, -3, AS/NZS 61000-3-2, -3
 IEC 61000-4-2, -3, -4, -5, -6, -8, -11, EN 61547:2009
 AS/NZS CISPR 15:2011







DALI Standards and Compliance

IEC 62386-101 Ed 2 (DALI-2)
 IEC 62386-102 Ed 2 (DALI-2)
 IEC 62386-208 (DALI Switching Function)

EU Directives

2014/35/EU Low Voltage
 2014/30/EU Electromagnetic Compatibility (EMC)
 2015/863 Restriction of Hazardous Substances (RoHS) in Electrical and Electronic Equipment

Specifications

Number of Switched Outputs	DGOZ-DINRLY-12A-01: 1 DGOZ-DINRLY-12A-02: 2
DALI Compatibility	DALI and DALI-2
DALI Operating Voltage	16 V dc (nominal), with suitable operation from 9.5 V – 22.5 V
DALI Line Current Draw	2 mA
DALI Mains tolerance	DALI input is mains voltage tolerant
DALI Device Type	Type 7
Mains Supply Voltage	100 – 240 V ac
Mains Frequency Range	47 – 63 Hz
Electrical Isolation	2 kV (Channel Input/Output Terminals to DALI and to Mains)
Status Indicators	Power & DALI - Green Each Channel - Green
Load Rating	AC loads: Resistive, Inductive, Fluorescent, LED, Capacitive: 12 A per channel Motor: 2 A (1 hp) per channel
Inrush Current Rating	500 A (2 ms)
Relay Switch Operations	> 50 000 operations at rated load
Relay Contact Type	Bifurcated High Inrush
Relay Switching Type	Zero voltage detection for relay turn-on.
Relay Terminals Polarity	Non-polarised
Standby Power	< 150 mW
DALI line terminals	2 x 2.5 mm ² maximum per terminal or 3 x 1.5 mm ² maximum per terminal
Mains supply terminals	2 x 2.5 mm ² maximum per terminal or 3 x 1.5 mm ² maximum per terminal
Ambient operating temperature	0 - 50°C
Humidity	0% to 95% RH non-condensing
Ingress protection	IP20
Materials	Enclosure/fascia – flame resistant polycarbonate DIN rail clip – ABS
Weight	1 Channel: 105 g 2 Channel: 120 g
Dimensions – 2 DIN modules	92 x 37.5 x 62.2 (H x W x D in millimetres)
Approvals	     

Dimensions

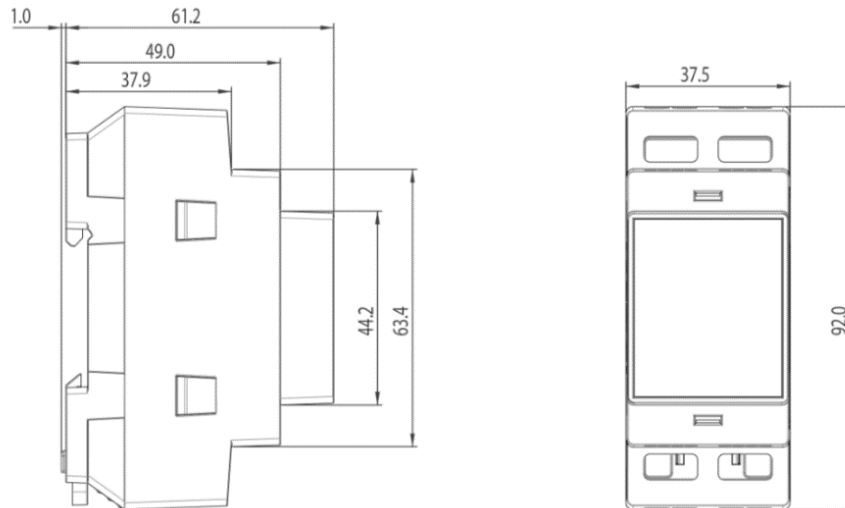

Warranty

This product has a TWO YEAR warranty against manufacturing defects. The warranty applies from the date of purchase.

Refer to ozuno.com for the full conditions for warranty and returns process. A summary of the process:

1. Contact the seller of the goods, or in their absence contact Ozuno to request a return goods authorisation.
2. When a return is authorised, the goods must be returned to Ozuno at the owner's expense for technical evaluation.
3. The warranty claim will be evaluated by Ozuno and accepted if the goods are found to be faulty, or rejected if the fault was caused by conditions beyond the responsibility of Ozuno. Considerations of installation, removal, return, freight and testing are not the responsibility of Ozuno.

The Australian Consumer Law requires the inclusion of the following statement with this Warranty:

Our goods come with guarantees that cannot be excluded under the Australian Consumer Law. You are entitled to a replacement or refund for a major failure and for compensation for any other reasonably foreseeable loss or damage. You are also entitled to have the goods repaired or replaced if the goods fail to be of acceptable quality and the failure does not amount to a major failure.



Ozuno Trading Pty Ltd (Ozuno) reserves the right to alter the specifications, designs or other features of any items and to discontinue any items at any time without notice and without liability. While every effort is made to ensure that all information in this user and installation guide is correct, no warranty of accuracy is given and Ozuno shall not be liable for any error.

Trademarks

RAPIX is a trademark of Ozuno Holdings Limited.

Identified trademarks and copyrights are the property of Ozuno Holdings Limited unless otherwise noted.

© Copyright

This guide is copyright to Ozuno Holdings Limited. Except as permitted under relevant law, no part of this guide may be reproduced by any process without written permission and acknowledgement to Ozuno Holdings Limited.

Sales: Ozuno Trading Pty Ltd, ABN 96 621 194 483

Contact

Technical Support: support@ozuno.com

